



## AUTOMATIZACIÓN DE PRENSAS SL

### COMPACT FEED LINE FOR UNWINDING, STRAIGHTENING AND FEEDING IN ONE UNIT FOR VERY REDUCED SPACE

Our customer **MARTISA**, a leading company in the metal stamping sector, came to us with a clear goal: to install a **short feeding line** in a very small space.

For this, we have designed a short compact feeding line for unwinding, straightening and feeding in one unit, consisting of: A decoiler for 6000 kg and 1600 mm outer diameter coils, model DEMA-6000/85/750-CD, with mechanical expansion of the mandrel by hydraulic drive, motorized hydraulic arm, electronic speed variator and adjustable speed control, mobile loading cart with speed up to 3 mts / min; with compact straightener-feeder for materials of width 800 mm, thickness 4 mm and maximum section of 1.800 mm<sup>2</sup>, model EMAE-85/750 with Motor-Drive control and frame with adjustable height. Space saver system designed to straighten and feed into a single unit. Easy to install and program, with the introduction of the first loop of the strap, which allows easy sliding of the material to the straightener-feeder without the need for the operator to manipulate the strap avoiding unnecessary risks.

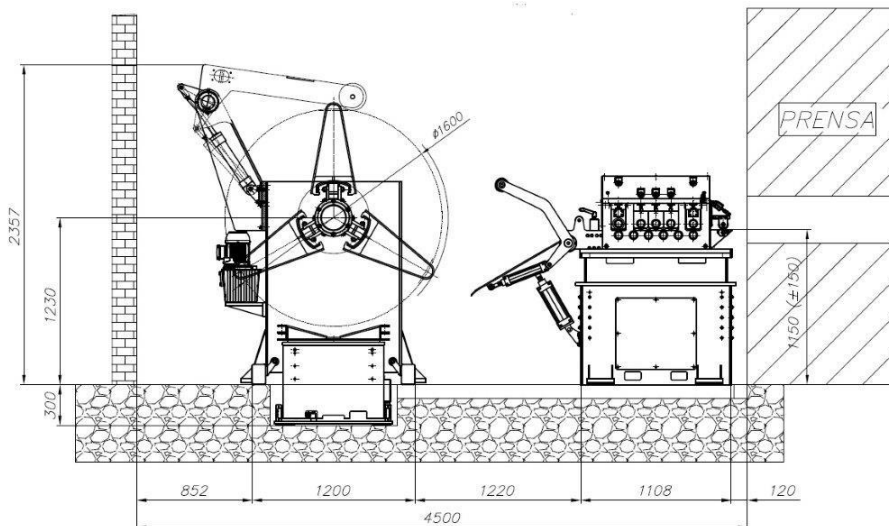

VISIT OUR WEBSITE

[www.lara-spain.com](http://www.lara-spain.com)

If you need any further information, do not hesitate to contact us. Our commercial team will be assists you for any information you may require.

Tel. +34937195502 / +34937291224 Fax. +34937188032 [info@lara-spain.com](mailto:info@lara-spain.com)

You are receiving this newsletter because your data is in our customer/supplier data base. Aren't you interested for any longer? To quit your data from our distribution list, click [here](#).